



EV9100-01

# A-10 10" Clear Housing

Clear filter housing



A-10 10" Clear Housing: EV9100-01

## BENEFITS

- 10" utility housing
- Holds any 10" drop-in filter or softening cartridge
- Clear bowl with mounting bracket
- Versatile basic design accommodates many applications

## INSTALLATION TIPS

- Install vertically so bowls hang down.
- Allow 2-1/2" clearance below the cartridge for easy cartridge replacement
- Make sure o-ring on bowl is sufficiently lubricated
- Always screw on bowls by hand; Do not use a housing wrench.

## OPERATION TIPS

- Change cartridges on a regular 6 month preventative maintenance program
- Change cartridges according to cartridge specifications

## APPLICATION/SIZING

- For foodservice applications
- Utility housing holds most 10" drop in cartridges

# A-10 10" Clear Housing

## SPECIFICATIONS

Overall Dimensions: 12-1/2"H x 4-7/8"W x 4-7/8"D

Inlet connection: 3/8"

Outlet connection: 3/8"

Service Flow Rate: Maximum 5 gpm (19 Lpm)

Pressure Requirements: 10 psi -125 psi  
(0.7 – 8.6 bar), non-shock

Temperature: 35°F - 100°F (2-38°C)

No electrical connection required

Shipping Weight: 4 lbs.

Operating Weight: 5 lbs.

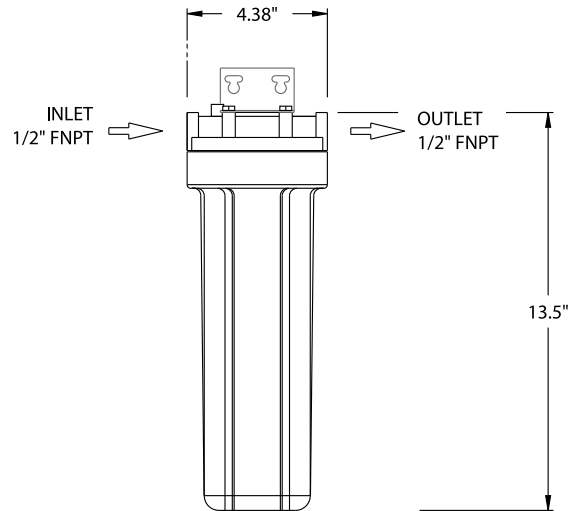

## WARRANTY

Everpure water treatment systems (excluding replaceable elements) are covered by a limited warranty against defects in material and workmanship for a period of five years after date of purchase. Everpure replaceable elements (filter cartridges and water treatment cartridges) are covered by a limited warranty against defects in material and workmanship for a period of one year after date of purchase. See printed warranty for details. Everpure will provide a copy of the warranty upon request.

**EVERPURE**

EVERPURE, LLC  
1040 Muirfield Drive  
Hanover Park, Illinois 60133  
Toll Free (800) 323-7873  
Tel (630) 307-3000  
Fax (630) 307-3030  
<http://www.everpure.com>

*In Europe:*  
N.V. EVERPURE (EUROPE) S.A.  
INDUSTRIEPARK WOLFSTEE  
TOEKOMSTLAAN 30  
B-2200 HERENTALS  
BELGIUM  
TEL 32 -14-283500  
FAX 32-14-283505

*In Japan:*  
EVERPURE JAPAN LLC  
HASHIMOTO MN BLDG. 7F  
3-25-1 HASHIMOTO SAGAMIHARA-SHI  
KANAGAWA 229-1103  
JAPAN  
TEL 81-(0)42-775-3011  
FAX 81-(0)42-775-3015

**FILTER PURE SYSTEM**  
**5405 BORAN PLACE**  
**TAMPA, FL 33610**  
**Phone: 800-942-7873 Fax: 888-942-7873**